

NOTE: FLASHER AND FLASHER CONNECTOR ARE NOT INCLUDED WITH SWITCHES. USE No.9186 CONNECTOR ASSEMBLY WHEN REQUIRED.

Federal-Mogul Document #4200

How to wire Model 900,901 and 910 switch

1. Mount switch on steering column.
2. Remove flasher during wiring. Replace flasher only after wiring is completed and checked.
3. Wire as indicated in accompanying diagram A.
4. Tape ends of unused wires to prevent shorts.
5. Replace flasher to complete installation.

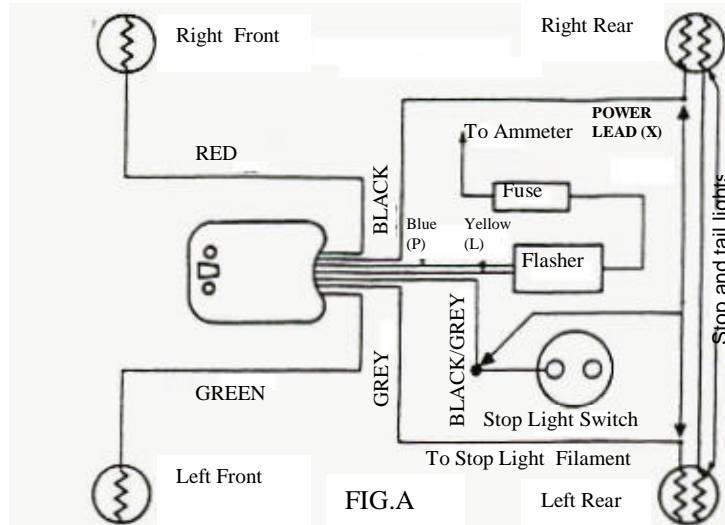

FIG. A

How to wire Model 902 and 903 Switch

1. Mount switch on steering column.
2. Remove flasher from harness during wiring. Replace after wiring has been completed and checked.
3. Wire as indicated in accompanying diagram B.
4. Replace flasher to complete installation.

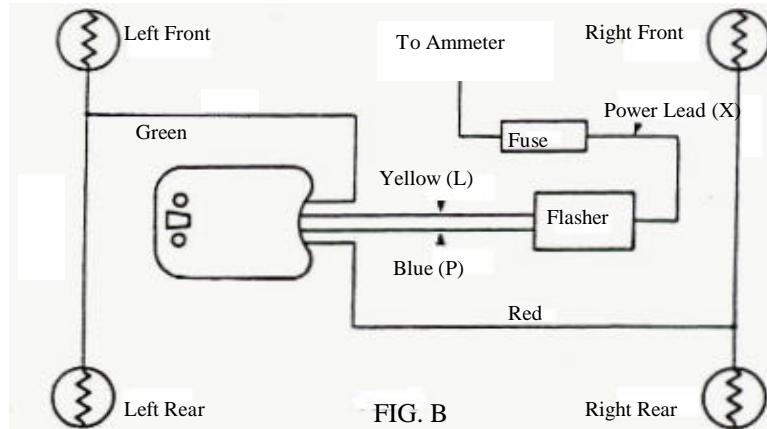

FIG. B

How to wire Model 905 Switch

1. Mount switch on steering column.
2. Wire turn signal and hazard warning functions as indicated for 900 Switch in Fig. A.
3. Disconnect ground cable from battery.
4. Wire headlight Hi/Lo beam circuit as indicated on accompanying diagram C.
5. Replace ground cable to complete installation.

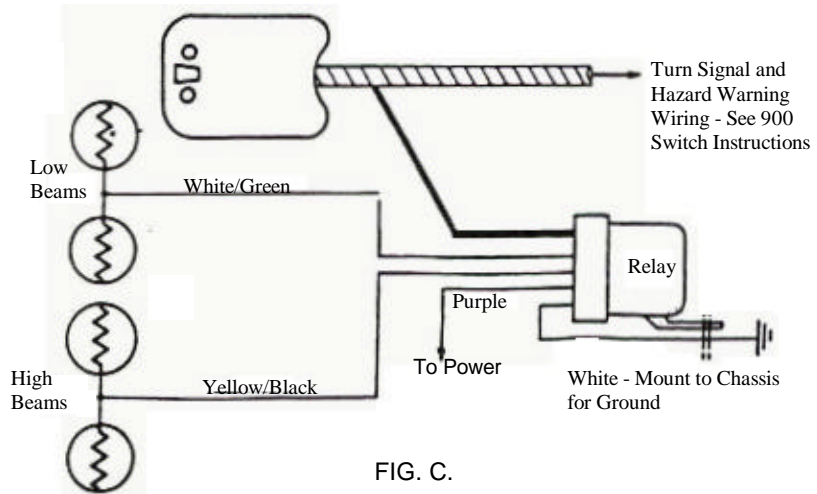

FIG. C.

NOTE: USE NO. 9191 FOR REPLACEMENT HANDLE AND HI-LO BEAM SWITCH.

**Federal-Mogul Corporation
Signal-Stat Division**

Serviceman: Give this instruction sheet to the vehicle owner.

Please Note: All switches are used with three prong flashers marked, (X) = power, (L) = Load, (P) = Pilot

900 SERIES SWITCH

